

Rollixo RTS

Roller Garage Door Control System



Electrical safety edge transmitter



Optical safety edge transmitter



Control buttons and LED diagnostic interface on the front panel.

The next generation Roller Garage Door Controller

- Quick & simple installation
 - > Wireless safety edge: no wiring between the receiver and the safety edge
 - > Plug-in mains power supply cable
 - > Removable terminal connectors
 - > Factory pre-programmed remote controls
- Intelligent feedback, guaranteed efficiency
 - > Real-time feedback with each installation step:
 - Motor direction of rotation setting
 - Motor end-limits setting
 - Safety edge transmitter programming
 - Remote control programming
- Clever diagnostics
 - > Status indication of each system component:
 - Motor and safety brake
 - Safety edge and photocells
 - Battery level
- Universal solution
 - > Compatible with all safety edges:
 - Wireless or wired
 - Optical or resistive
 - > Wide range of safety and control accessories
- Garage door security
 - > Intruder alarm warns against any attempt to lift the door with a 100dB sounder
- Quality and convenience
 - > Control buttons on front panel
 - > Integral courtesy light
 - > Battery powered wireless safety edge transmitter: 5-year battery lifetime
 - > Automatic switch to a safe operating mode (dead man) in the event of a security device failure

Dimensions & Technical Specification

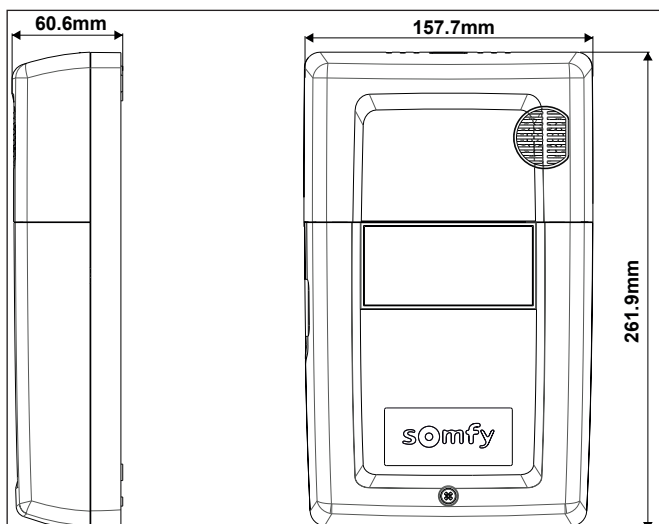

Mains power supply	230Vac - 50/60 Hz
Maximum motor voltage	230Vac - 750W
Radio frequency	RTS: 433.42 MHz
Maximum number of controls	32
Operating temperature	-20°C to +60°C
Index of protection	IP 20
Integral light	230Vac - 25W maximum - E14
Safety inputs	3 dry contact inputs (N/C) for: <ul style="list-style-type: none"> • Wired safety edge: optical or resistive • Safety brake • Photocells
Wired control input	Dry contact input: N/O